

Les Laminoirs

Puissance et fiabilité



^{GB} Sheeter *Power and reliability*

Technical Specifications

- Ground, chromium-plated lamination cylinders
- Easily dismantled scrapers, quick and easy cleaning
- Fold-away (LB-LT-LF) and removable surfaces (LF)
- Variable speed belt on the whole range
- Manual control on the machine and by pedal, series (LF-LT)
- Available in versions with a single speed or continuous, variable speed
- Optional cutting unit on the machines with variable speed, series LF

F

Caractéristiques Techniques

- Cylindres de laminage chromés et rectifiés
- Racleurs facilement démontables, nettoyage facile et rapide
- Tables repliables (LB/LT/LF) et amovibles (LF)
- Tapis à vitesse différentielle sur toute la gamme
- Commandes manuelle et au pied par pédale de série (LF/LT)
- Disponibles en 1 vitesse ou vitesse variable
- Système de découpe en option sur les gammes LF à variateur



F **Gamme LB, LT**

Les lamineurs, séries LB et LT, largeur de tapis 500 mm, sont les machines idéales pour le laminage de tous les types de pâte. Ils sont destinés aux laboratoires de pâtisserie et boulangerie, mais aussi aux hôtels, restaurants et pizzerias. Ils se caractérisent par une construction simple et fiable, un entretien et un nettoyage faciles. Ils sont disponibles en version à poser sur table et en version sur socle avec roulettes.



GB **LB, LT Series**

The manual sheeter LB and LT series, belt width 500 mm, are the ideal machines for rolling all types of pulp. They are intended for pastry shops and bakeries, but also hotels, restaurants and pizzerias. They are characterized by a simple and reliable structure, easy maintenance and cleaning. They are available in posing on table and version on base with wheels.

LB500



LT500



*Largeur cylindres
Cylinders width*

*Longueur tapis
Belt length*

500	500	700	850	1000	1200
-----	-----	-----	-----	------	------



F *Gamme LF*

Les laminoirs de la série LF, tapis largeur 600 mm extractibles, commandes par solide basculeur et pédale, sont des machines destinées aux laboratoires importants. Conçus pour un travail intensif, avec motorisation dans le socle, ils peuvent être équipés d'un système de découpe performant (seulement sur tables 1200 et 1400 - modèle à variateur).



GB *LF Series*

The Manual shheter LF, width 600 mm removable carpet set, orders and solid rocker pedal, are machines for large laboratories. Designed for intensive work with engine in the base, they can be equipped with an efficient cutting system (only tables 1200 and 1400 - model drive).

Largeur cylindres
Cylinders width

Longueur tapis
Belt length

600	850	1000	1200	1400



LF600



Option / Optional

Groupe de découpe pour croissants, pain au chocolat, biscuits, etc. (LF600P/PM)

Cutting equipment for croissants, etc. (LF600P/PM)

Exemples de rouleaux de découpe
Examples of cutting rollerse



Caractéristiques Techniques / Technical Specifications

Modèle Model	Longueur tapis Belt length mm	Largeur cylindres Cylinders width mm	Ø Cylindres Ø Cylinders mm	Ouverture cylindres Cylinder aperture mm	Vitesse Speed	Vitesse tapis sortie Output belt speed m/min	Puissance Power kw	Volt Volts	Poids Weight kg
LB500-50	500	500	60	0-36	Fixe / Fix	35	0,55	400/50/3	150
LB500-70	700	500	60	0-36	Fixe / Fix	35	0,55	400/50/3	160
LB500-85	850	500	60	0-36	Fixe / Fix	35	0,55	400/50/3	165
LB500-100	1000	500	60	0-36	Fixe / Fix	35	0,55	400/50/3	170
LB500-120	1200	500	60	0-36	Fixe / Fix	35	0,55	400/50/3	180
LB500PM50	500	500	60	0-36	Variable	5-40	0,55	230/50-60/1	150
LB500PM70	700	500	60	0-36	Variable	5-40	0,55	230/50-60/1	160
LB500PM85	850	500	60	0-36	Variable	5-40	0,55	230/50-60/1	165
LB500PM100	1000	500	60	0-36	Variable	5-40	0,55	230/50-60/1	170
LB500PM120	1200	500	60	0-36	Variable	5-40	0,55	230/50-60/1	180
LT500-70	700	500	60	0-36	Fixe / Fix	35	0,55	400/50/3	190
LT500-85	850	500	60	0-36	Fixe / Fix	35	0,55	400/50/3	195
LT500-100	1000	500	60	0-36	Fixe / Fix	35	0,55	400/50/3	200
LT500-120	1200	500	60	0-36	Fixe / Fix	35	0,55	400/60/3	210
LT500P-70	700	500	60	0-36	Variable	5-40	0,55	400/50-60/3	190
LT500P-85	850	500	60	0-36	Variable	5-40	0,55	400/50-60/3	195
LT500P-100	1000	500	60	0-36	Variable	5-40	0,55	400/50-60/3	200
LT500P-120	1200	500	60	0-36	Variable	5-40	0,55	400/50-60/3	210
LT500PM70	700	500	60	0-36	Variable	5-40	0,55	230/50-60/1	190
LT500PM85	850	500	60	0-36	Variable	5-40	0,55	230/50-60/1	195
LT500PM100	1000	500	60	0-36	Variable	5-40	0,55	230/50-60/1	200
LT500PM120	1200	500	60	0-36	Variable	5-40	0,55	230/50-60/1	210
LF600-85	850	600	80	0-50	Fixe / Fix	35	0,75	400/50/3	250
LF600-100	1000	600	80	0-50	Fixe / Fix	35	0,75	400/50/3	250
LF600-120	1200	600	80	0-50	Fixe / Fix	35	0,75	400/50/3	260
LF600-140	1400	600	80	0-50	Fixe / Fix	35	0,75	400/50/3	270
LF600P-85	850	600	80	0-50	Variable	5-40	0,75	400/50-60/3	250
LF600P-100	1000	600	80	0-50	Variable	5-40	0,75	400/50-60/3	250
LF600P-120	1200	600	80	0-50	Variable	5-40	0,75	400/50-60/3	260
LF600P-140	1400	600	80	0-50	Variable	5-40	0,75	400/50-60/3	270
LF600PM85	850	600	80	0-50	Variable	5-40	0,75	230/50-60/1	250
LF600PM100	1000	600	80	0-50	Variable	5-40	0,75	230/50-60/1	250
LF600PM120	1200	600	80	0-50	Variable	5-40	0,75	230/50-60/1	260
LF600PM140	1400	600	80	0-50	Variable	5-40	0,75	230/50-60/1	270

Dimensions / Dimensions

Modèle Model	Dimensions / Dimensions cm							Poids Weight kg
	A	B	C	D	E	F	G	
LB500-50	50	50	112	-	38	70	92	150
LB500-70	50	70	152	-	38	70	92	160
LB500-85	50	95	207	240	38	70	92	165
LB500-100	50	110	237	270	38	70	92	170
LB500-120	50	130	277	310	38	70	92	180
LT500-50	50	50	112	145	58	138	92	180
LT500-70	50	70	152	185	58	138	92	190
LT500-85	50	95	207	240	58	138	92	195
LT500-100	50	110	237	270	58	138	92	200
LT500-120	50	130	277	310	58	138	92	210
LF600-85	60	97	207	259	62	117	106	250
LF600-100	60	112	237	289	62	117	106	250
LF600-120	60	132	277	329	62	117	106	260
LF600-140	60	152	217	369	62	117	106	270
LF600P-85	60	97	207	259	62	117	106	250
LF600P-100	60	112	237	289	62	117	106	250
LF600P-120	60	132	277	329	62	117	106	260
LF600P-140	60	152	217	369	62	117	106	270

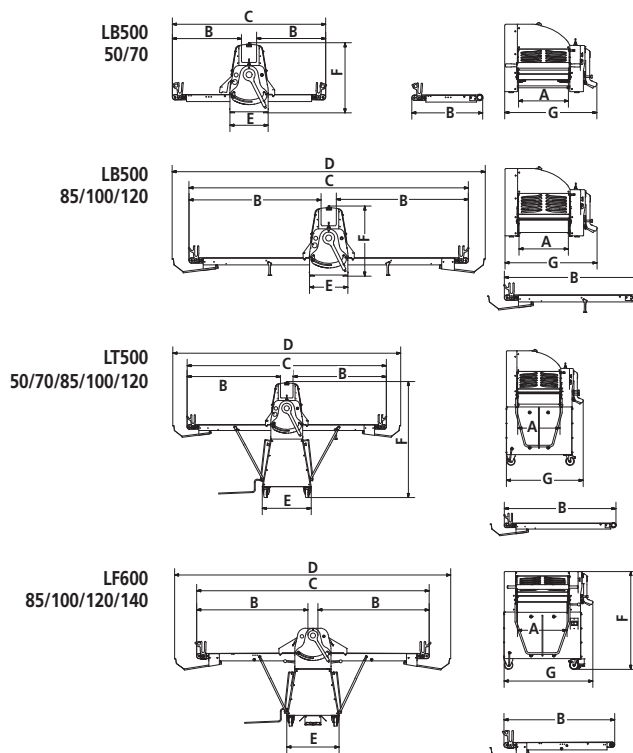

GECOMA

65, rue François Mouton - Z.I. LES ETAINGS - 42800 CHATEAUNEUF - FRANCE
 Tél. +33 (0) 4 77 75 29 69 - Fax +33 (0) 4 77 75 55 09
 contact@gecoma.net - www.gecoma.net