

GECOMA

Les Batteurs

Robustesse et Polyvalence

F Les batteurs mélangeurs de la Série BT, ont été conçus pour les pâtisseries moyennes, mais aussi les boulangeries importantes, les traiteurs, les restaurants. Très robustes, ils se distinguent par la flexibilité de leur fonctionnement et par la qualité élevée de leurs composants et équipements. Ils sont disponibles en version 12, 20, 40, 60 et 80 litres, avec possibilité de diverses réductions selon les modèles.



GB **Planetary mixer**

Robustness and versatility

The BT series of planetary mixers has been designed for small to medium bakery shops and it sets itself apart thanks to its flexibility of operation and the high quality of its components. The mixers are available in 20, 40, 60 and 80 liter sizes with the possibility of a bowl reduction kit.



Caractéristiques Techniques

- Modèle «T»: 3 vitesses électriques (BT20-40-60-80)
- Modèle «P»: Vitesse variable en continu par variateur (BT12-20-40-60-80)
- Modèle «E»: 4 vitesses programmées + vitesse variable en continu par variateur à commande numérique, 99 programmes de travail (BT40-60-80)
- Montée/descente de la cuve par vérin et levier

EQUIPEMENTS DE SERIE

- Cuve, fouet inox, crochet et spatule aluminium (BT20-40-60)
- Cuve, fouet renforcé inox, crochet et spatule inox (BT80)

EQUIPEMENTS EN OPTION

- «V»: Montée/descente électrique de la cuve (BT40-60-80)
- Kits de réduction (Cuve, fouet, crochet, spatule): 80-60L, 80-40L, 60-40L, 60-20L, 40-20L, 40-10L, 2010L

BT12B-20B



BT12B-20B
Accrochage outil
Tool hooking system

BT20



BT40



BT40-60-80
Accrochage outil
Tool hooking system



BT40-60-80
Protection cuve démontable
Detachable bowl safety



BT40-60-80
Réduction cuve
Bowl reduction system



BT40-60-80
Blocage automatique cuve
Bowl automatic locking

Technical Specifications

- "T" - 3 electric speeds (BT20-40-60-80)
- "P" – continuous speed with manual control inverter "P" (BT20-40-60-80)
- "E" – continuous speed with digital control inverter, 99 operating cycle programs + 4 preset speeds (BT40-60-80)

STANDARD EQUIPMENTS

- Bowl, fine wire whisk, aluminum hook and spatula (BT20-40-60)
- Bowl, fine wire whisk, stainless steel hook and spatula (BT80)

OPTIONAL EQUIPMENTS

- "V" – electric bowl lifting (BT40-60-80)
- Reduction kit (bowl + whisk + hook + spatula) 80-60 lt, 80-40 lt, 60-40 lt, 60-20 lt, 40-20 lt, 40-10 lt, 20-10 lt

BT60-80



T

BT20T, BT40T, BT60T, BT80T

Tableau de commande à 3 vitesses et 1 Minuter / Control panel with 3 speeds and 1 Timer



P

BT20PM, BT20P, BT40P, BT60P, BT80P

Tableau de commande à variation manuelle et 1 Minuter
Control panel with manual adjustment and 1 Timer



E

BT40E, BT60E, BT80E

Tableau de commande numérique à programmeur + 4 vitesses
Digital control panel with programmer + 4 speeds

BT80PVH-EVH



BT80PVH-EVH

Blocage automatique cuve
Bowl automatic locking



Caractéristiques Techniques / Technical Specifications

Modèle Model	Capacité Capacity lt	Vitesse Speed	Volt	Soulèvement cuve Bowl lifting	Puissance Power kw	Dimensions Dimensions mm			Poids Weight kg	Dim. emballage Package dim. mm			P. avec emb. W. with pack. kg
						A	C	B		A	C	B	
BT12B	12	Vitesse variable / Variable speed	230/50/1	Fixe / Fix	0,55	500	400	630	46	
BT20B	20	Vitesse variable / Variable speed	230/50/1	Fixe / Fix	0,55	600	470	711	56	
BT20T	20	3	400/50/3	Manuel/Manual	0,5/0,75/1,1	700	500	1200	110	810	580	1400	140
BT20PM	20	Vitesse variable / Variable speed	230/50/1	Manuel/Manual	0,75	700	500	1200	110	810	580	1400	140
BT20P	20	Vitesse variable / Variable speed	400/50/3	Manuel/Manual	0,75	700	500	1200	110	810	580	1400	140
BT40T	40	3	400/50/3	Manuel/Manual	0,75/1/1,3	910	650	1520	250	1010	750	1730	295
BT40P	40	Vitesse variable / Variable speed	400/50/3	Manuel/Manual	2,2	910	650	1520	250	1010	750	1730	295
BT40E	40	Var. digit. + 4 vit. / Digit. + 4 sp.	400/50/3	Manuel/Manual	2,2	910	650	1520	250	1010	750	1730	295
BT40TV	40	3	400/50/3	Electrique/Electric	0,75/1/1,3	910	650	1520	250	1010	750	1730	305
BT40PV	40	Vitesse variable / Variable speed	400/50/3	Electrique/Electric	2,2	910	650	1520	250	1010	750	1730	305
BT40EV	40	Var. digit. + 4 vit. / Digit. + 4 sp.	400/50/3	Electrique/Electric	2,2	910	650	1520	250	1010	750	1730	305
BT60T	60	3	400/50/3	Manuel/Manual	1,1/1,5/1,7	1000	680	1600	280	1160	810	1750	340
BT60P	60	Vitesse variable / Variable speed	400/50/3	Manuel/Manual	3	1000	680	1600	280	1160	810	1750	340
BT60E	60	Var. digit. + 4 vit. / Digit. + 4 sp.	400/50/3	Manuel/Manual	3	1000	680	1600	280	1160	810	1750	240
BT60PV	60	Vitesse variable / Variable speed	400/50/3	Electrique/Electric	3	1000	680	1600	280	1160	810	1750	350
BT60TV	60	3	400/50/3	Electrique/Electric	1,1/1,5/1,7	1000	680	1600	280	1160	810	1750	350
BT60EV	60	Var. digit. + 4 vit. / Digit. + 4 sp.	400/50/3	Electrique/Electric	3	1000	680	1600	280	1160	810	1750	350
BT80T	80	3	400/50/3	Manuel/Manual	1,1/1,5/1,7	1000	680	1600	290	1160	810	1750	350
BT80P	80	Vitesse variable / Variable speed	400/50/3	Manuel/Manual	3	1000	680	1600	290	1160	810	1750	350
BT80E	80	Var. digit. + 4 vit. / Digit. + 4 sp.	400/50/3	Manuel/Manual	3	1000	680	1600	290	1160	810	1750	350
BT80TV	80	3	400/50/3	Electrique/Electric	1,1/1,5/1,7	1000	680	1600	290	1160	810	1750	360
BT80PV	80	Vitesse variable / Variable speed	400/50/3	Electrique/Electric	3	1000	680	1600	290	1160	810	1750	360
BT80EV	80	Var. digit. + 4 vit. / Digit. + 4 sp.	400/50/3	Electrique/Electric	3	1000	680	1600	290	1160	810	1750	360
BT80PVH	80	Var. digit. + 4 vit. / Digit. + 4 sp.	400/50/3	Electrique/Electric	3 *	1000	680	1800	330	1160	810	1750	360
BT80EVH	80	Var. digit. + 4 vit. / Digit. + 4 sp.	400/50/3	Electrique/Electric	3 *	1000	680	1800	330	1160	810	1750	360

"T" 3 vitesses / 3 speeds

"P" Variation continue manuelle / Continuous manual adjustment

"E" Variation continue numérique / Continuous digital adjustment

"TV" 3 vitesses-cuve électrique / 3 speed electrical bowl

"PV" Variation continue manuelle-cuve électrique / Continuous manual adjustment for electrical bowl

"EV" Variation continue numérique-cuve électrique / Digital manual adjustment for electrical bowl

* Sur demande / On demand 5,5 kw

Outils / Tools



Cuve / Bowl



Fouet fils minces
Fine wire whisk



Crochet / Hook



Spatule / Spatula

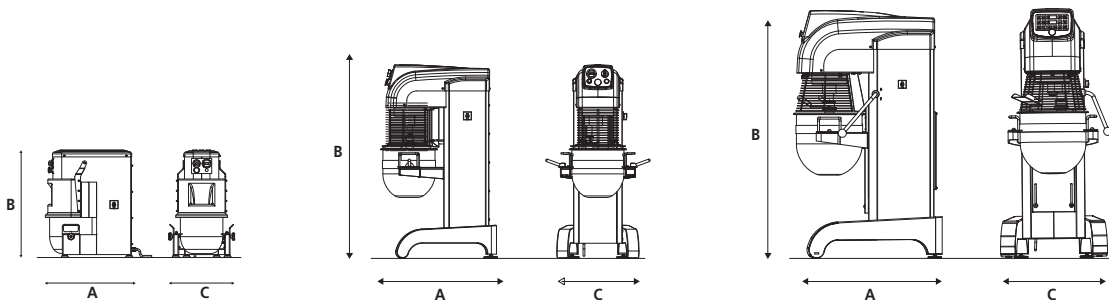

BT12B/20B

BT20

BT40-60-80

GECOMA

65, rue François Mouton - Z.I. LES ETAINGS - 42800 CHATEAUNEUF - FRANCE
Tél. +33 (0) 4 77 75 29 69 - Fax +33 (0) 4 77 75 55 09
contact@gecoma.net - www.gecoma.net